

FDMQ EI 90 S (Lightweight Wall - Fire Batt Fire stop)

Used materials - example:

- 3 Hilti CFS-CT B 1S 140/50
- 4 Hilti CFS-CT

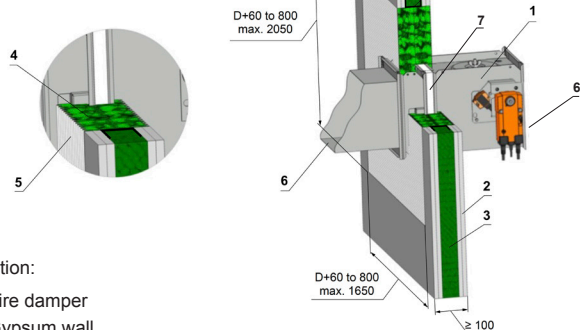

Position:

- 1 Fire damper
- 2 Gypsum wall
- 3 Mineral wool (type depending on the type of construction)
- 4 Fire resistant board
- 5 Fire stop coating thickness 1mm
- 6 DW144 standard duct supported to flanged breakaway joint on both front and rear of damper
- 7 Damper and duct connection in wall line to be solid fixings

Wall build construction must be symmetrical and in accordance with BS EN 1363-1 and tested in accordance with BS EN 1364-1. FDMQ lightweight wall minimum thickness is 100mm

FDMQ can be installed with blade axis positioned either vertically or horizontally and with the actuator positioned at 0°, 90° or 270°, but not at 180°.

Detail of plasterboard construction according to Rigips instructions (substitutes can be used that have a minimum of 2 x 12.5mm gypsum boards per side, such as British Gypsum, Knauf or Lafarge products that are the same overall wall thickness & EI performance).

Builders work opening

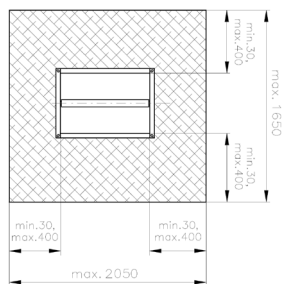

Fire Batt sizes can be rotated

Built in edge

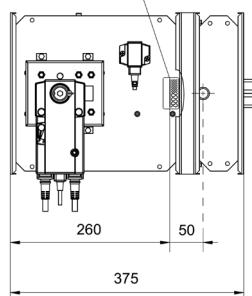

Built in edge signifies depth of damper insertion into wall

Fire batt installed as manufactures installation details

Drop rod and hanger location, please ensure that actuator operation is not compromised and ensure sufficient space to allow access hatch removal.

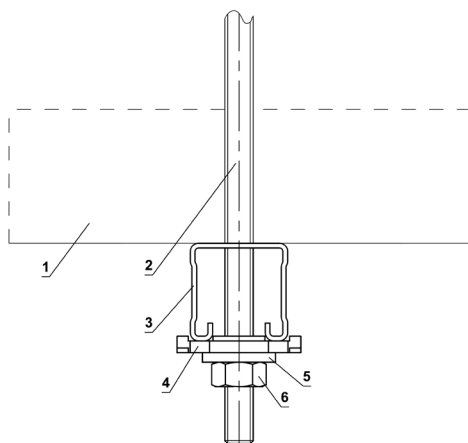

Drop rod and hanger position is not critical and can be positioned to suit the particular installation, applying symmetry where possible.

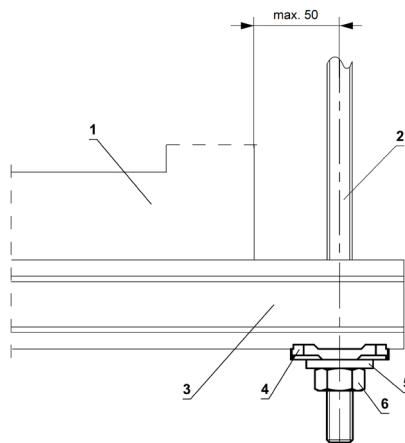

Position:

- 1 FDMQ
- 2 Threaded rod M8 - M20
- 3 Support HILTI (MQ-41 = <math>< 100\text{kg}</math>) or (MQ-41/3 = $> 100\text{kg}$)
- 4 Bored plate HILTI MQZ-L
- 5 Washer for M8 - M20
- 6 Nut M8 - M20

Advice provided by a fixing specialist contractor takes precedence.

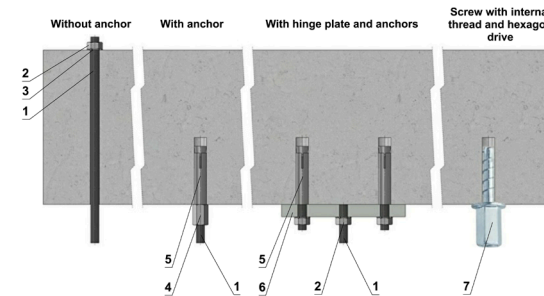

Hinge plates

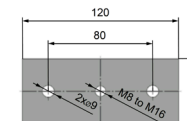

Screw with internal thread and hexagon drive

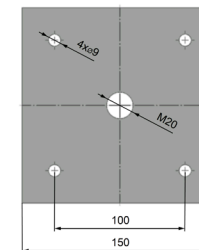
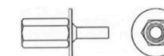

Load capacities of threaded hanger rods F [N] at the required fire resistance 90 minutes

Size	As [mm]	Weight G [kg]	
		for 1 piece	for 1 pair
M8	36.6	22	44
M10	58	35	70
M12	84.3	52	104
M14	115	70	140
M16	157	96	192
M18	192	117	234
M20	245	150	300

Position:

- 1 Threaded rod M8 - M20
- 2 Nut
- 3 Washer
- 4 Coupling nut
- 5 Anchor
- 6 Hinge plate - min. thickness 10mm
- 7 Concrete screw tested for fire resistance R30-R90, max. tension up to 0.75KN (length 35mm)

Drop rod diameter is based on damper weight, see full Damper TPM for further technical details or contact help@Mandik.co.uk. Mandik reserves the right to update this information without prior notice.

		Mandik UK Ltd www.mandik.co.uk Office: 0117 4526376	Redwood House Brotherswood Court Great Park Road Almondsbury Bristol BS32 4QW
		CE certified acc. to EN 15650 Tested in accordance with EN 1366-2	
Title: FDMQ - Lightweight wall/ Fire Batt		Classification: EI 90 (ve i<->o) S	
Drawing No: 0000-0000-010 Rev 4		Size: (min-max) 150x150 - 1500x800	Date: 29/10/2021
Intellectual property of MANDIK Ltd. Unauthorised use shall be punishable by law		Illustrated: GP	Approved: MF